

TECHNICAL SPECIFICATIONS, BAGGER:

- WEIGHT: 1184 lbs [537 kg]
- ELECTRICAL: 100/115/200/230 VAC @ 50/60 Hz
- AIR: 1 CFM @ 80 PSI [28 litre/min @ .55 MPA] (CLEAN, DRY AIR)
- PRODUCT PASS THROUGH: 6" [15,2 cm]
- PRODUCT WEIGHT CAPACITY: UP TO 15 lbs [6,8 kg] W/ SUPPORT CONVEYOR

PRINTER:  
VIDEOJET DATAFLEX 6420  
2.1" [53MM] AND 4.2" [107MM] 300 DPI PRINTHEADS AVAILABLE  
PLEASE SEE WWW.VIDEOJET.COM FOR DETAILS

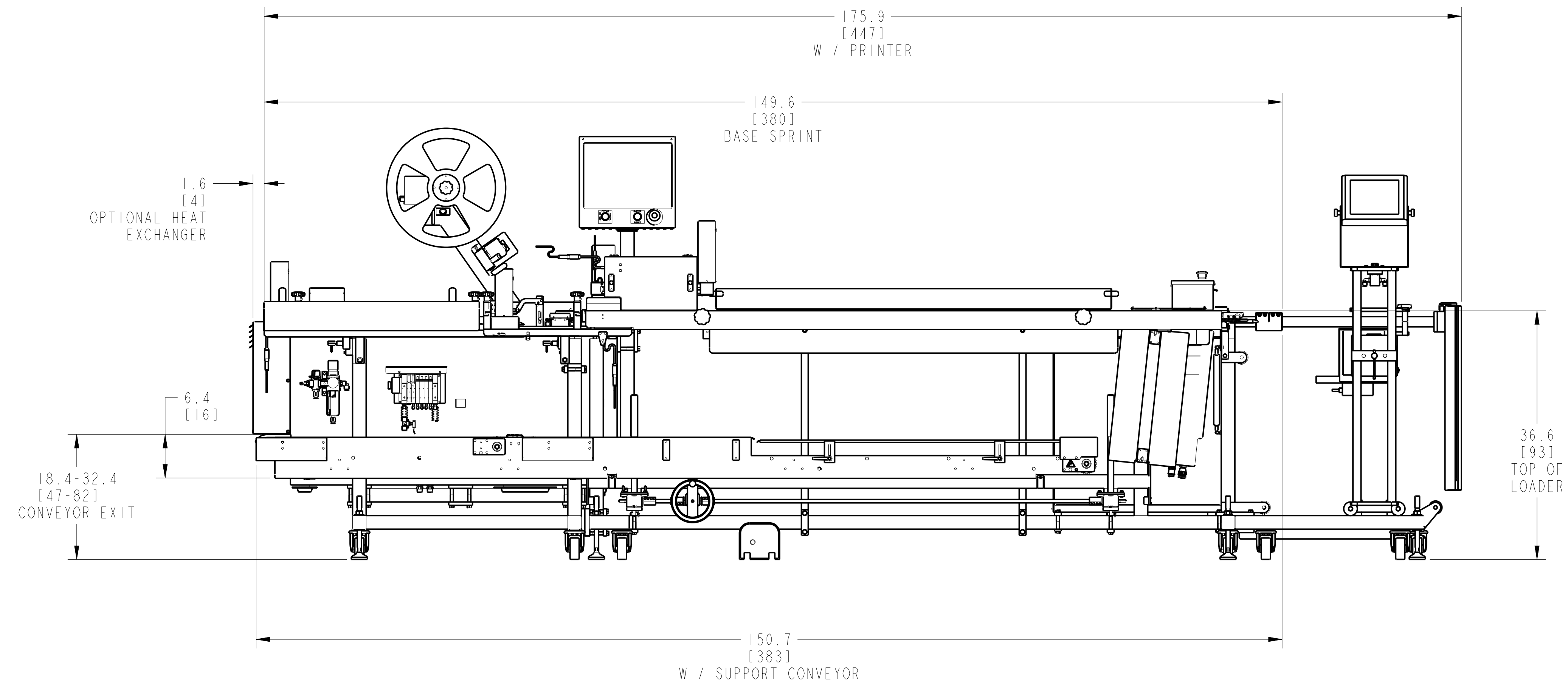
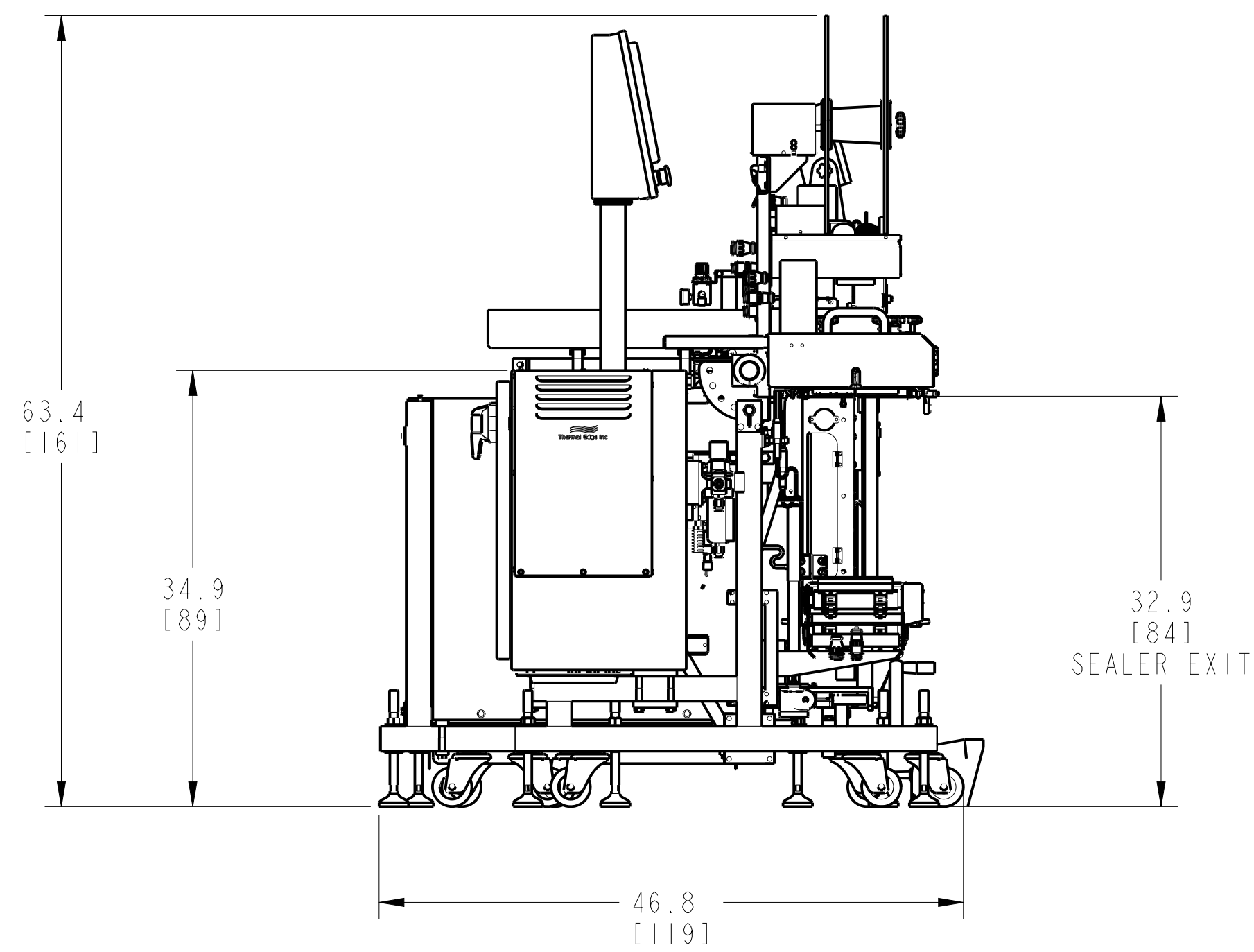
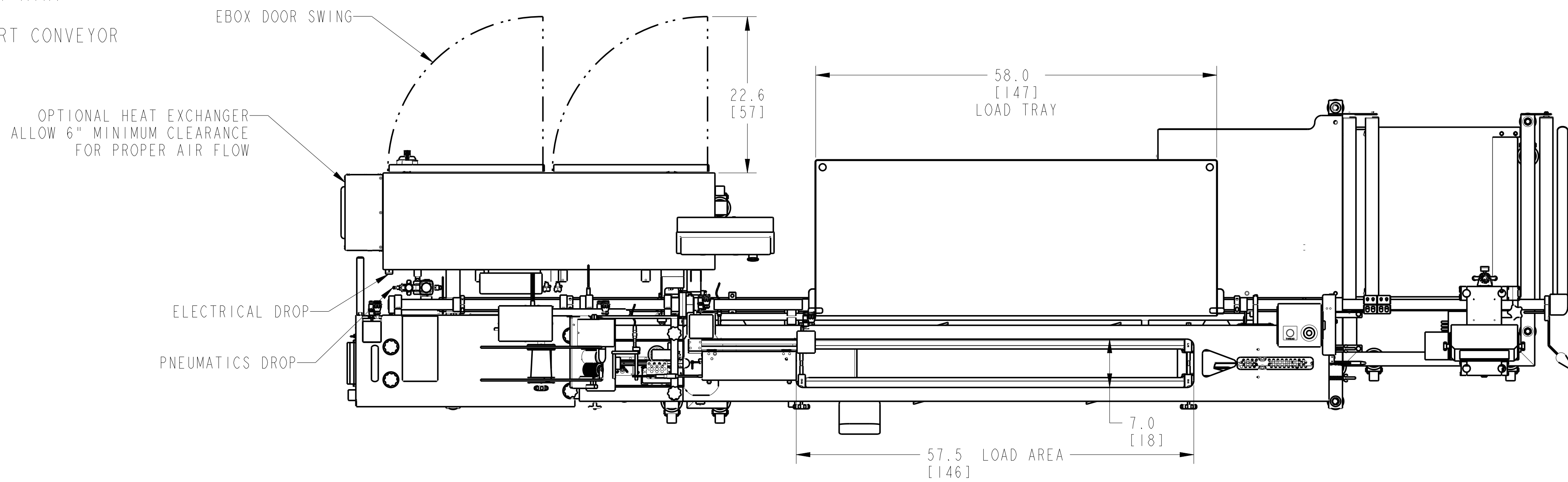

Fabricated & Documented to be RoHS Compliant

INCH [CM]

FINISH	NONE
MATERIAL	N/A
MACHINE SURFACES TO BE NO GREATER THAN 125 13.21 ✓ UNLESS OTHERWISE NOTED PART MUST BE FREE OF BURRS AND SHARP EDGES	
TOLERANCE	INCHES mm
1 PLACE DIMS	± .1 ±0.5
2 PLACE DIMS	± .02 ±0.51
3 PLACE DIMS	± .005 ±0.10
ANGULAR	± 1/2°
NOTICE: THIS DOCUMENT CONTAINS PROPRIETARY INFORMATION AND IT SHALL NOT BE USED OR REPRODUCED OR ITS CONTENT DISCLOSED, IN WHOLE OR PART, WITHOUT THE PRIOR WRITTEN CONSENT OF AUTOMATED PACKAGING SYSTEMS, INC.	
INCH [MM]	THIRD ANGLE PROJECTION

REV	BY	DATE	ECN	DESCRIPTION
C	CW	8-25-17	1203	CORRECTED BASE MACHINE AND TURN BAR DEPICTION, ADDED OPT. HEAT EXCHANGER
B	CW	3-2-16	438	ADDED PRINTER INFORMATION
DRAWING NO. SHEET 1 OF 1				
TITLE: FAS SPRINT 2009 W/ OPTIONS				REV: C
DRAWING NO. FP209				BOM REFERENCE NUMBER: N/A
<p>Automated Packaging Systems 10175 PHILIPP PARKWAY • STREETSBORO, OH 44241</p>				
DRAWING SIZE	SCALE	DATE	DATE	DATE
D	3/32	09-09-09	09-09-09	09-09-09