

Automated Mailer System

PriorityPak®

Automated
Ready-To-Ship
Packaging

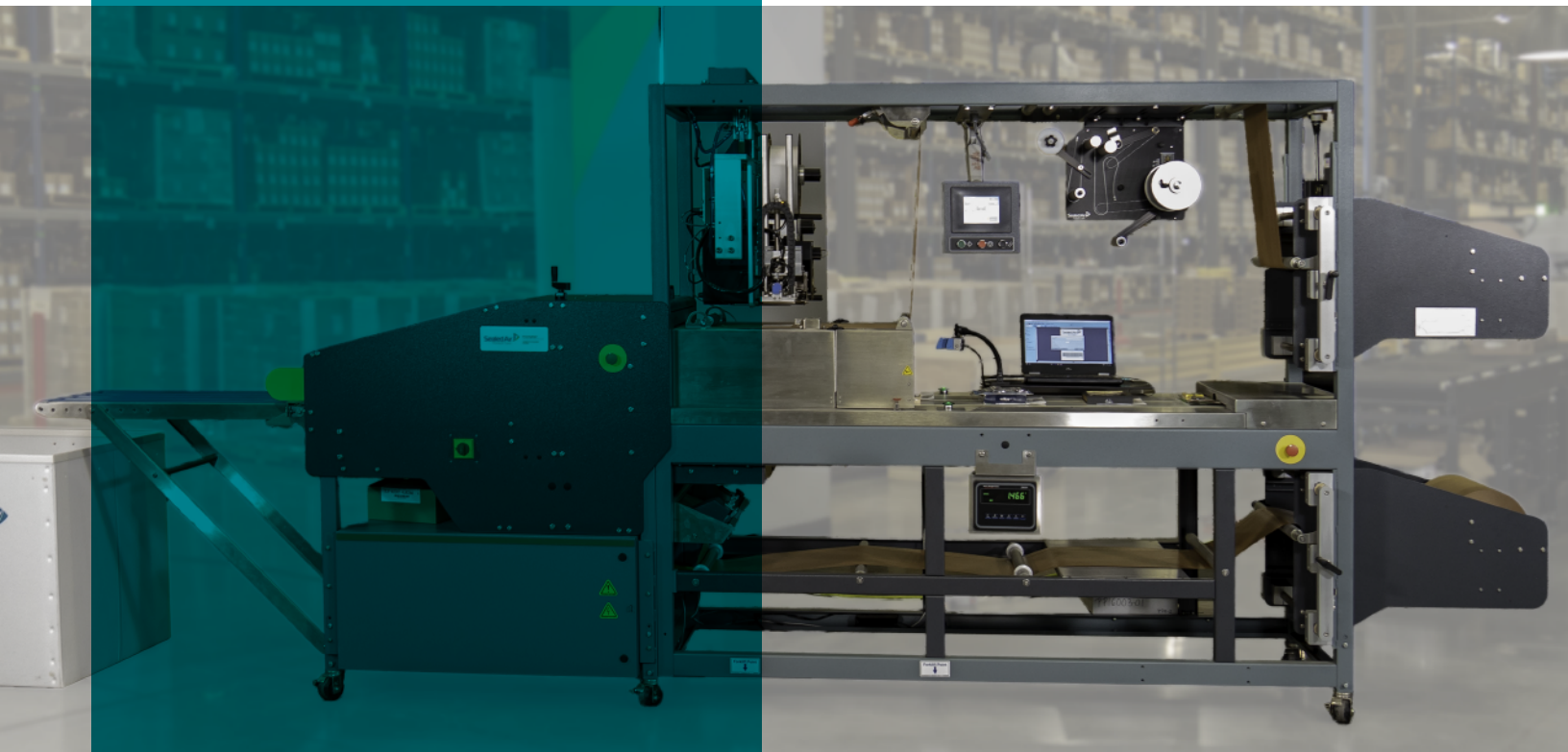
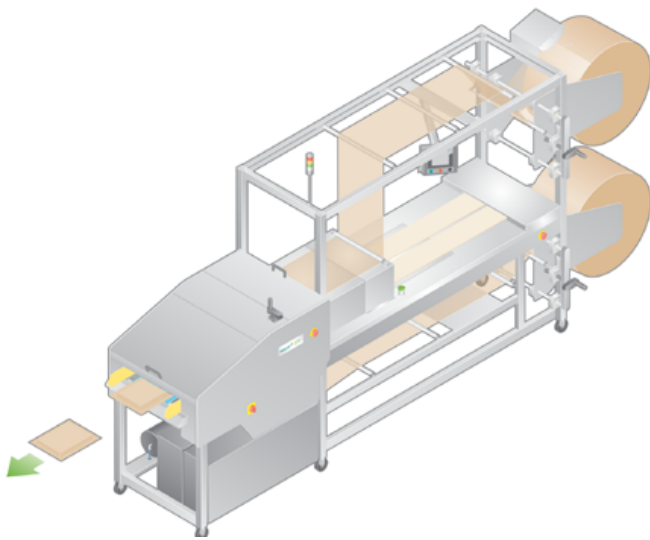

The PriorityPak® system encapsulates your products in a Cold Seal® cohesive - coated protective package that locks and seals products in place to minimize shifting inside the package, providing superior product protection.



PriorityPak® Automated Mailer System



PriorityWrap® Bubble Laminate



PriorityWrap® Rigid Board

INCREASES PRODUCTIVITY

The PriorityPak system reduces pack time and maximizes labor by creating up to 14 ready-to-mail packages a minute (compared to one to three packages a minute with manual packaging methods). The system automatically weighs and scans each product while applying a shipping label to the parcel.

EASY TO USE

Just plug it in, connect to compressed air, load and feed the material rolls. Operator training is needed for product placement. No complex settings or need to adjust for sizes or volume.

SYSTEM CUSTOMIZATION

The PriorityPak system can be used at pack stations or seamlessly integrated into existing packaging lines, interfacing with other automated equipment.

CHOICE OF MATERIALS

Sealed Air's PriorityPak system uses three types of protective packaging materials. The strong and versatile PriorityWrap® Bubble Laminate is perfect for products requiring both containment and cushioning. PriorityWrap Rigid Board is ideal for applications requiring containment, inflexibility and surface protection. PriorityWrap Single Face provides excellent surface protection and crush resistance. Additionally, easy-open tear strips and perforations can be integrated into each material.

SUSTAINABILITY

PriorityWrap Rigid Board material is certified curbside recyclable.