

TECHNICAL SPECIFICATIONS - BAGGER:
 - WEIGHT: 375 lbs [181kg]
 - ELECTRICAL: 115 VAC; 60 Hz ; 20 A
 - AIR: 5 CFM@60 PSI CLEAN DRY AIR
 - PRODUCT PASS THROUGH: 5 IN [12,7 cm]

TECHNICAL SPECIFICATION - PRINTER:
 - WEIGHT: 206 lbs [93 kg]
 - ELECTRICAL: 115/230 VAC; 50/60 Hz
 - AIR: LESS THAN 5 CFM@80 PSI CLEAN DRY AIR
 - LABEL SIZE: UP TO 4 IN WIDE [10 cm]
 UP TO 20 IN LONG [50,8 cm]

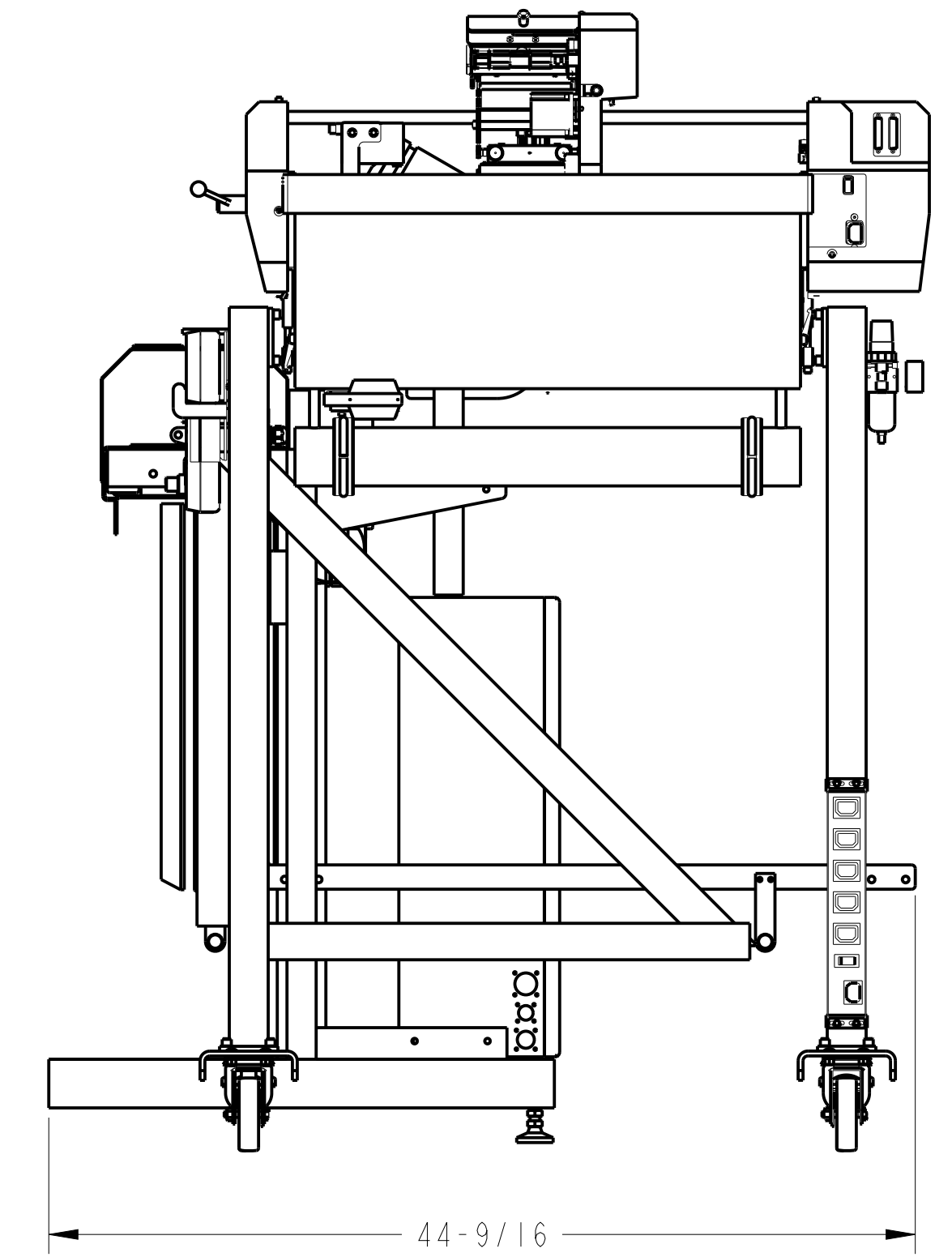
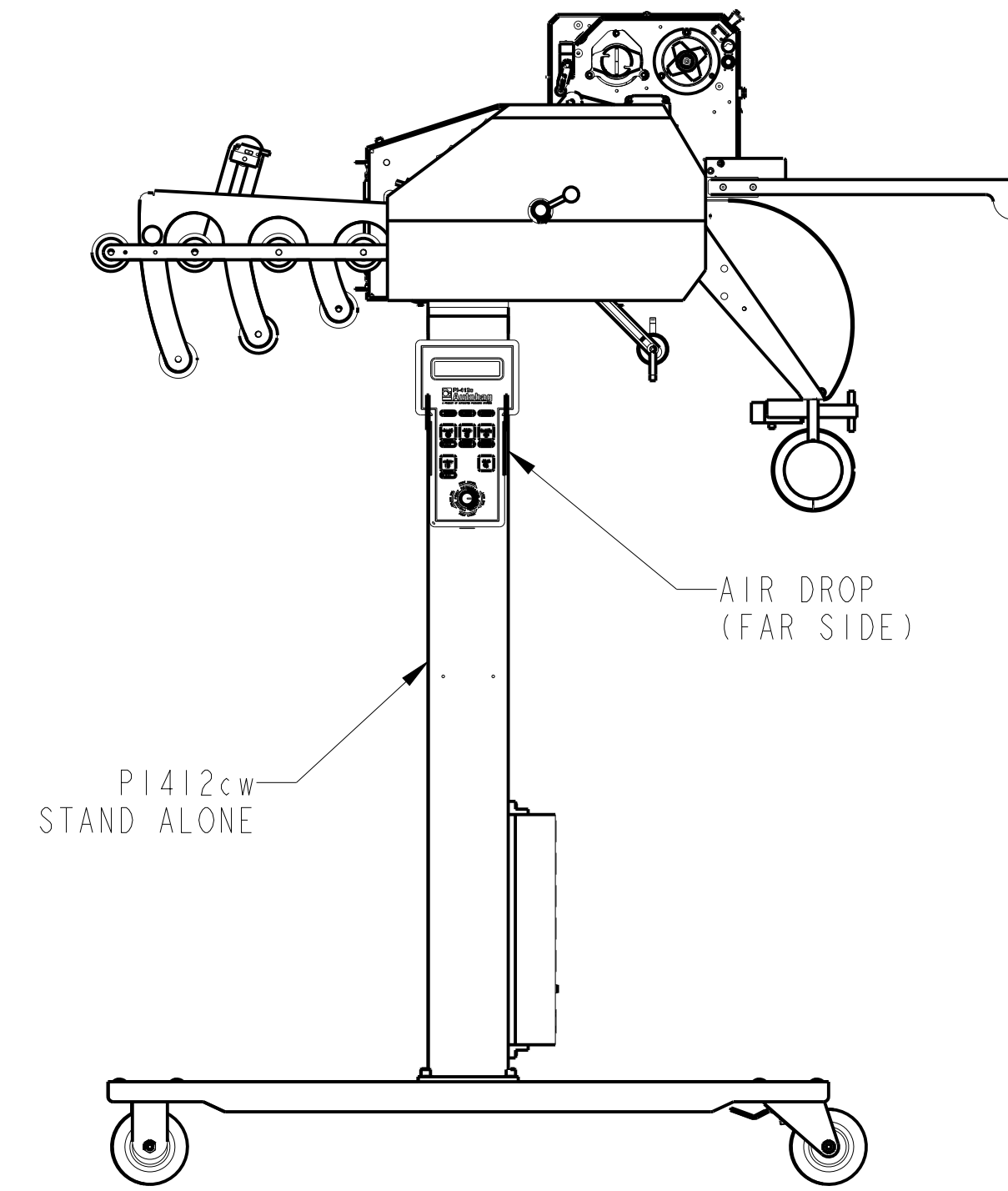
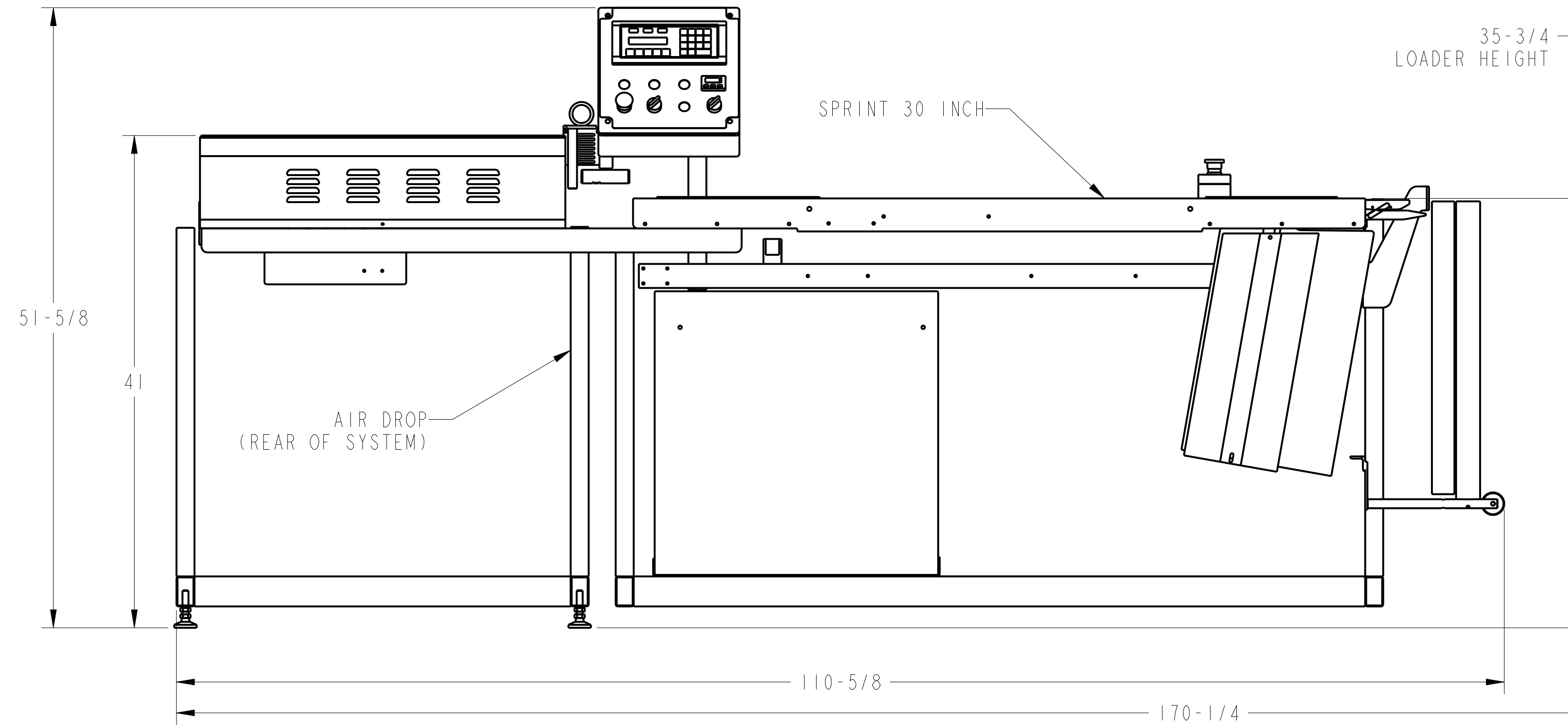
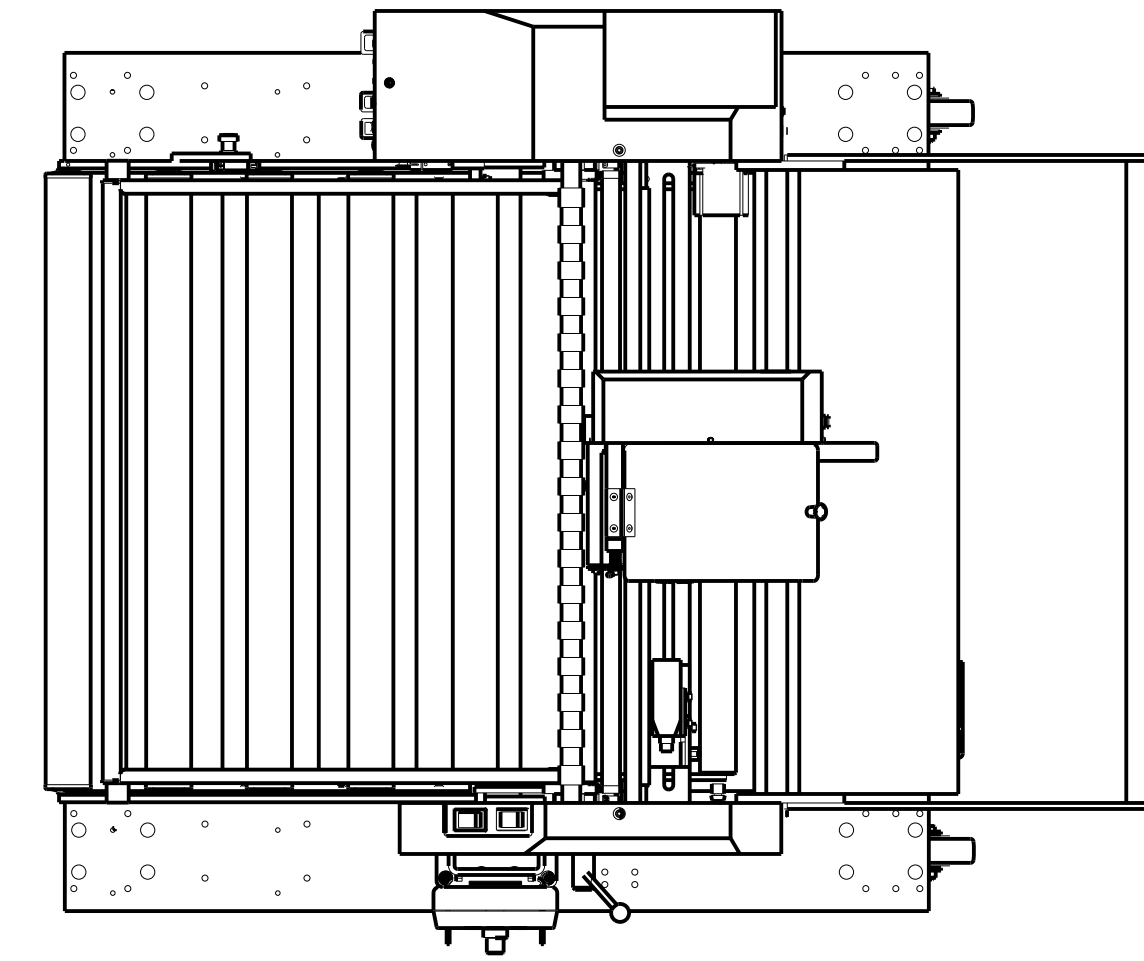
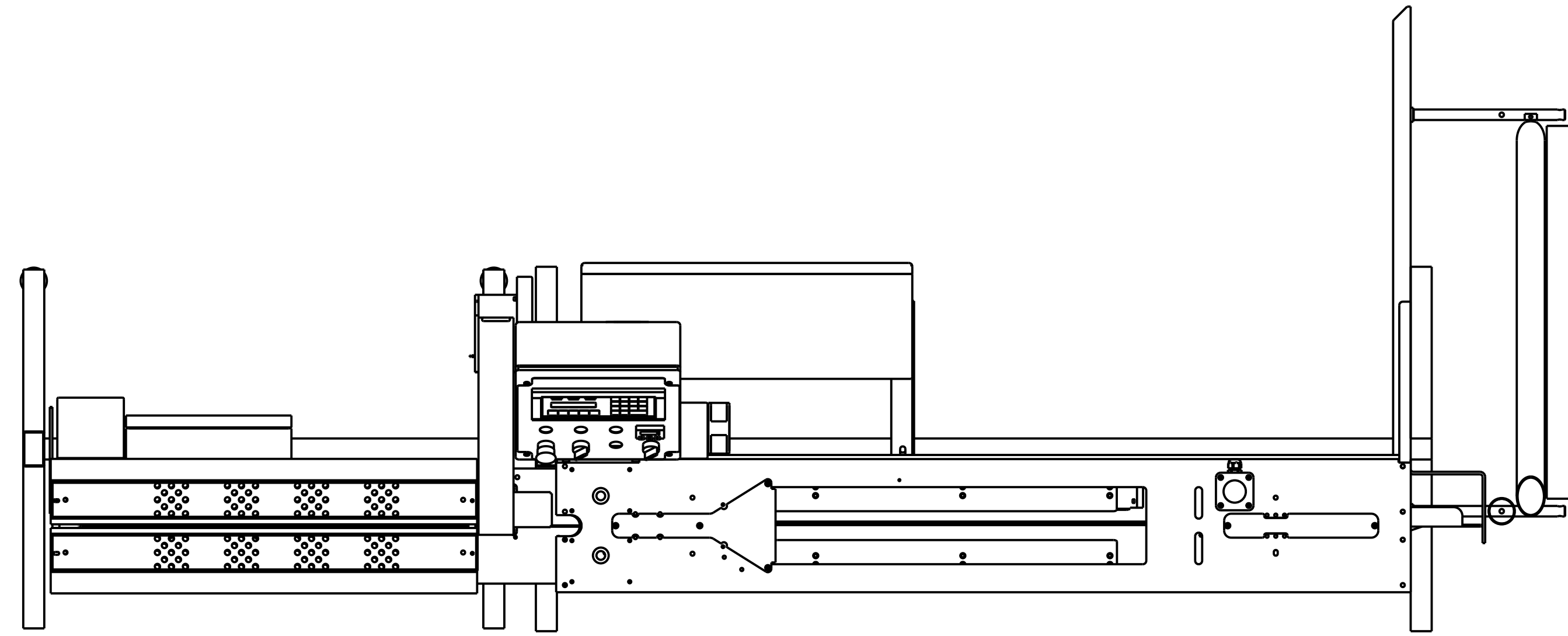

Fabricated & Documented to be RoHS Compliant

FINISH	NONE
MATERIAL	SPRINT SYSTEM
MACHINE SURFACES TO BE NO GREATER THAN 125 13.21 ✓ UNLESS OTHERWISE NOTED PART MUST BE FREE OF BURRS AND SHARP EDGES	
TOLERANCE	INCHES mm
1 PLACE DIMS	±.01 ±.25
2 PLACE DIMS	±.02 ±.51
3 PLACE DIMS	±.005 ±.10
ANGLES	± 1/2°
NOTICE: THIS DOCUMENT CONTAINS PROPRIETARY INFORMATION AND IT SHALL NOT BE USED OR REPRODUCED OR ITS CONTENT DISCLOSED, IN WHOLE OR PART, WITHOUT THE PRIOR WRITTEN CONSENT OF AUTOMATED PACKAGING SYSTEMS INC.	
INCH [MM]	THIRD ANGLE PROJECTION

A		CW	4-19-17	1006	RELEASED
REV	BY	DATE	ECN	DESCRIPTION	
 Automated PACKAGING SYSTEMS 10175 PHILIPP PARKWAY • STREETSBORO, OH 44241					
DRAWING SIZE	SCALE	DRAWN BY	BOM REFERENCE NUMBER		
D	1/8	NAME: DMF			
		DATE: 3-29-17			
TITLE		DRAWING NO.		SHEET 1 OF 1	
SPRINT, 30 INCH WITH P1412CW		FP144		REV	